

Installation and mounting manuals for **EK mosfet** water block:

This product is intended for expert users. Please consult with a qualified technician for installation. Improper installation may result in damage to your components. EK Water Blocks assumes no liability whatsoever, expressed or implied, for the use of these products, nor their installation. The following instructions are subject to change without notice. Please visit our web site at www.ekwaterblocks.com for updates.

Step 1:

Remove the motherboard from the computer and remove original heat sink and cut enclosed thermal pad on $7,5 \times 7,5$ mm and place them on red marked mosfet chips like shown on bottom image.

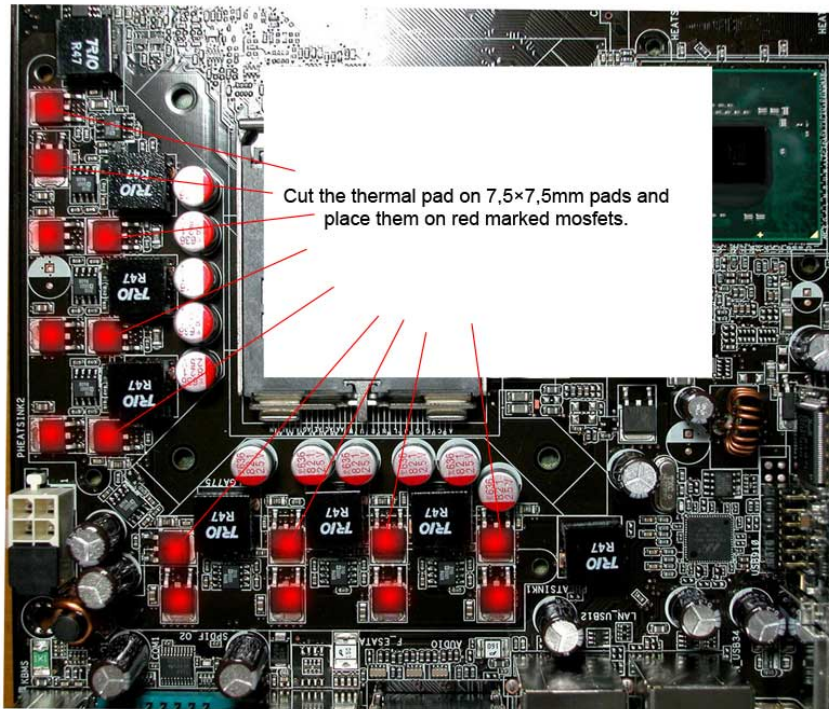

Use enclosed M3×8mm screws with metal and plastic washer to install the Mosfet cooler. Do not use high force to tighten the block.

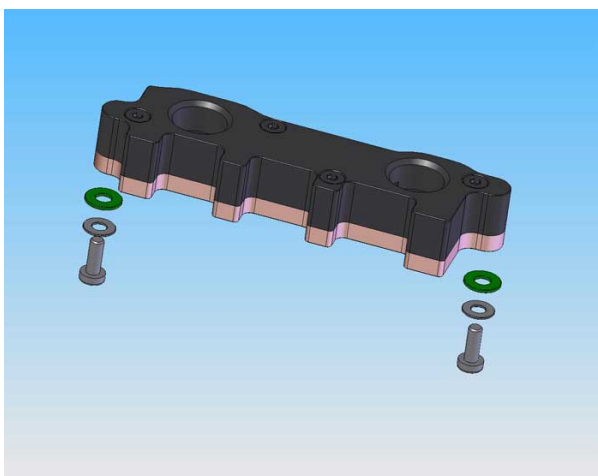

Mosfet Version 1

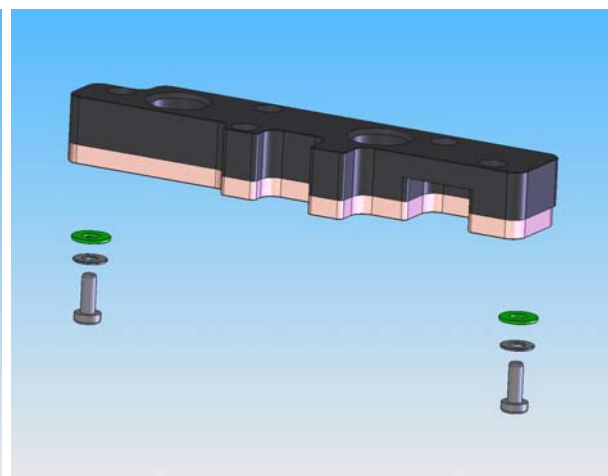

Mosfet Version 2

Chipset water block installation:

Clean the chipset core and apply thermal compound: lightly coat the Chipset core with for example Céramique™ thermal compound. Follow this link http://www.arcticsilver.com/ceramique_instructions.htm for detailed instructions. EK Water Blocks recommends non-conductive Arctic Sylver Céramique™.

There are two different types of NB/SB blocks:

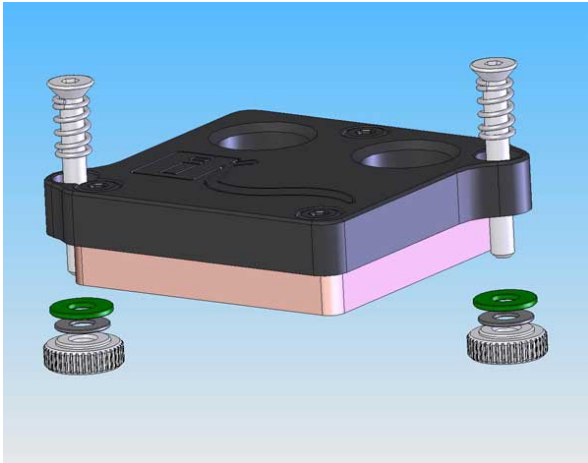

Chipset block version 1:

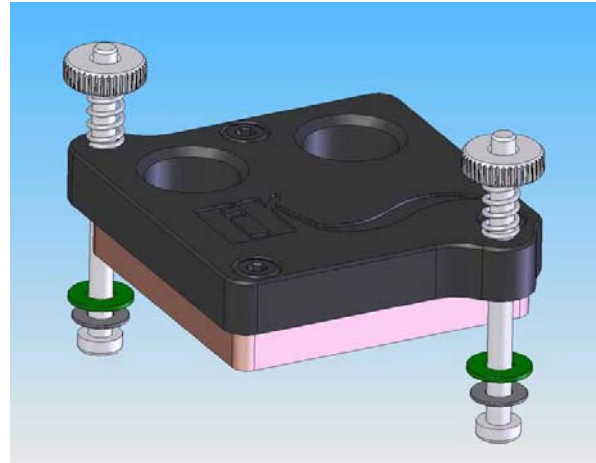

Chipset block version 2:

Version 1 is for chipset near the PCI-E slots, version 2 is for chipset near the CPU.

For Chipset Version 1, please use M3×25mm screws like on top left image.

For Chipset Version 2, please use M3×40mm screws like on top right image.

VERY IMPORTANT NOTICE

Once the installation is completed, it is always a good idea to test the circuit for leaks, prior to powering up the computer. We recommend a 24 hour leak test prior to powering up the computer. Do not test the water block using city water pressure. This will bow the top of the housing and render the block unusable (and will void your warranty).

IMPORTANT DISCLOSURES:

While all efforts have been made to provide the most comprehensive tutorial possible, EK Water Blocks assumes no liability expressed or implied for any damage(s) occurring to your components as a result of using EK Water Blocks cooling products, either due to mistake or omission on our part in the above instructions, or due to failure or defect in the EK Water Blocks cooling products.

WARRANTY:

Our products are guaranteed for 24 months from the date of delivery to the final user against defects in materials or workmanship. During this period, they will be repaired or have parts replaced provided that: (I) the product is returned to the agent from which it was purchased; (II) the product has been purchased by the end user and not used for hire purposes; (III) the product has not been misused, handled carelessly, or other than in accordance with any instructions provided with respect to its use. This guarantee does not confer rights other than those expressly set out above and does not cover any claims for consequential loss or damage. This guarantee is offered as an extra benefit and does not affect your statutory rights as a consumer. **The guarantee is not valid if there are used aggressive UV additives.**