

## Installation and mounting manuals for EK-FCR600 CF Xtreme water block:

This product is intended for expert users. Please consult with a qualified technician for installation. Improper installation may result in damage to your components. EK Water Blocks assumes no liability whatsoever, expressed or implied, for the use of these products, nor their installation. The following instructions are subject to change without notice. Please visit our web site at [www.ekwaterblocks.com](http://www.ekwaterblocks.com) for updates.

**If you need to screw in the fittings, please use small amount of force otherwise the high flow fittings might break. The fittings do not need to be tightened with high force.**

**Step 1.** Remove the graphic card from computer.

**Step 2.** Remove original heat sink and remove remains of original thermal compound. So the graphic card remains clean.

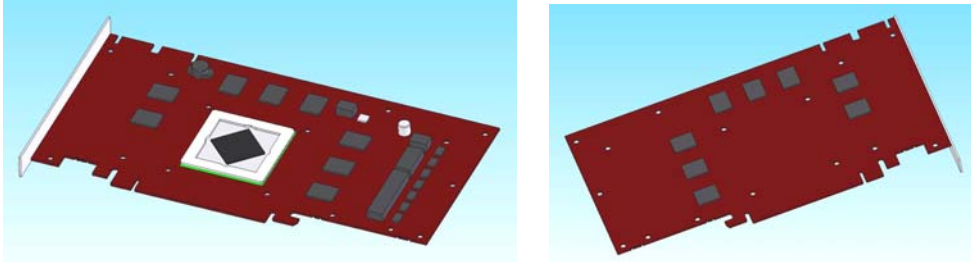

Picture 1 and 2: Radeon HD2900 TX series graphic card.

**Step 3.** Apply thermal compound: lightly coat the GPU, RAMs and Chip with for example Céramique™ thermal compound. Follow this link [http://www.arcticsilver.com/ceramique\\_instructions.htm](http://www.arcticsilver.com/ceramique_instructions.htm) for detailed instructions. EK Water Blocks recommends non-conductive Arctic Sylver Céramique™.

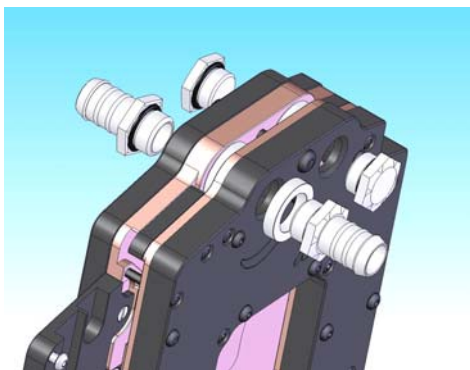

Picture 3: Installing fittings, plugs and spacers,

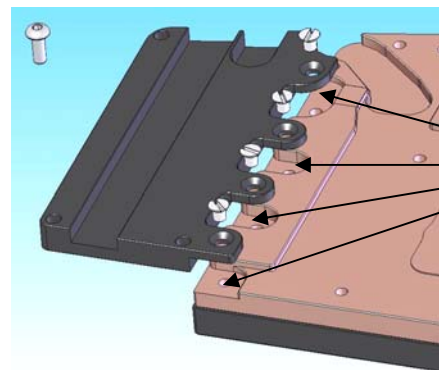

Picture 4: Alu part for mosfets

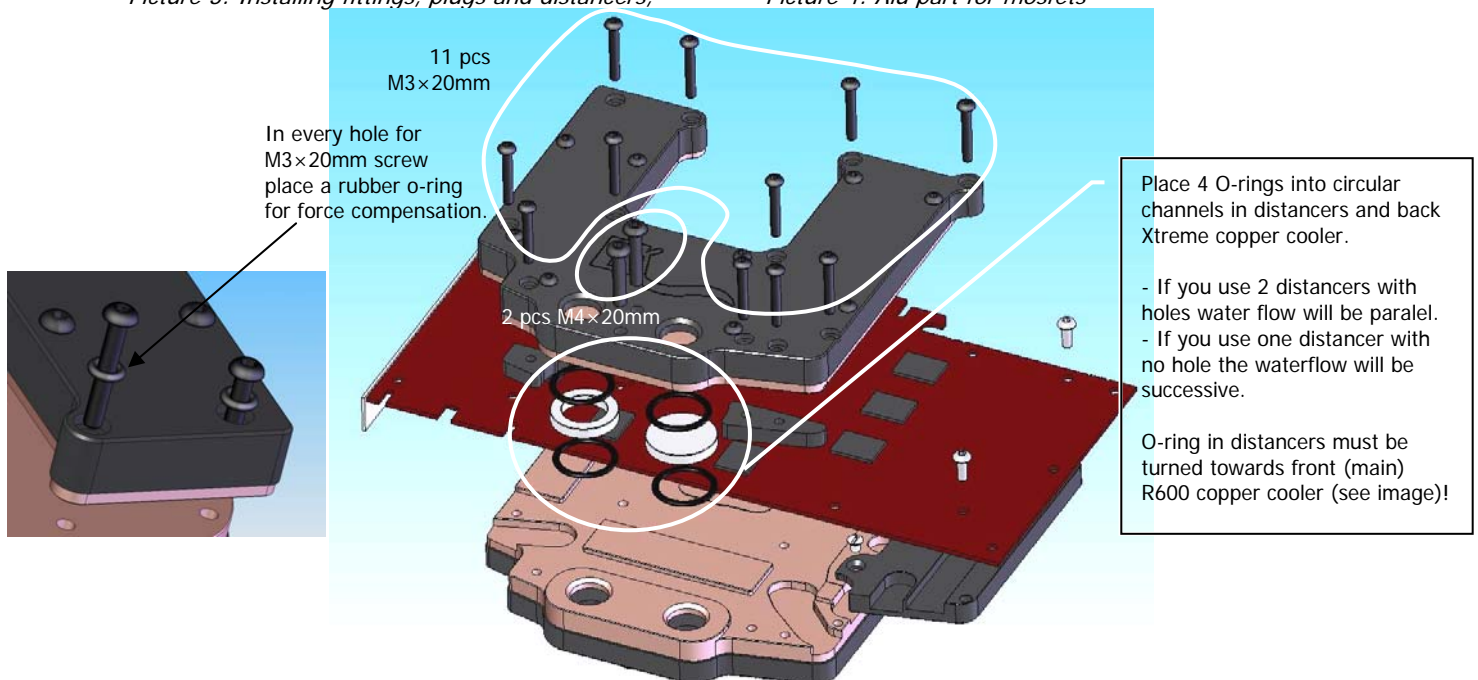

Picture 5: Radeon HD2900 TX series graphic card with assembling view - front side.

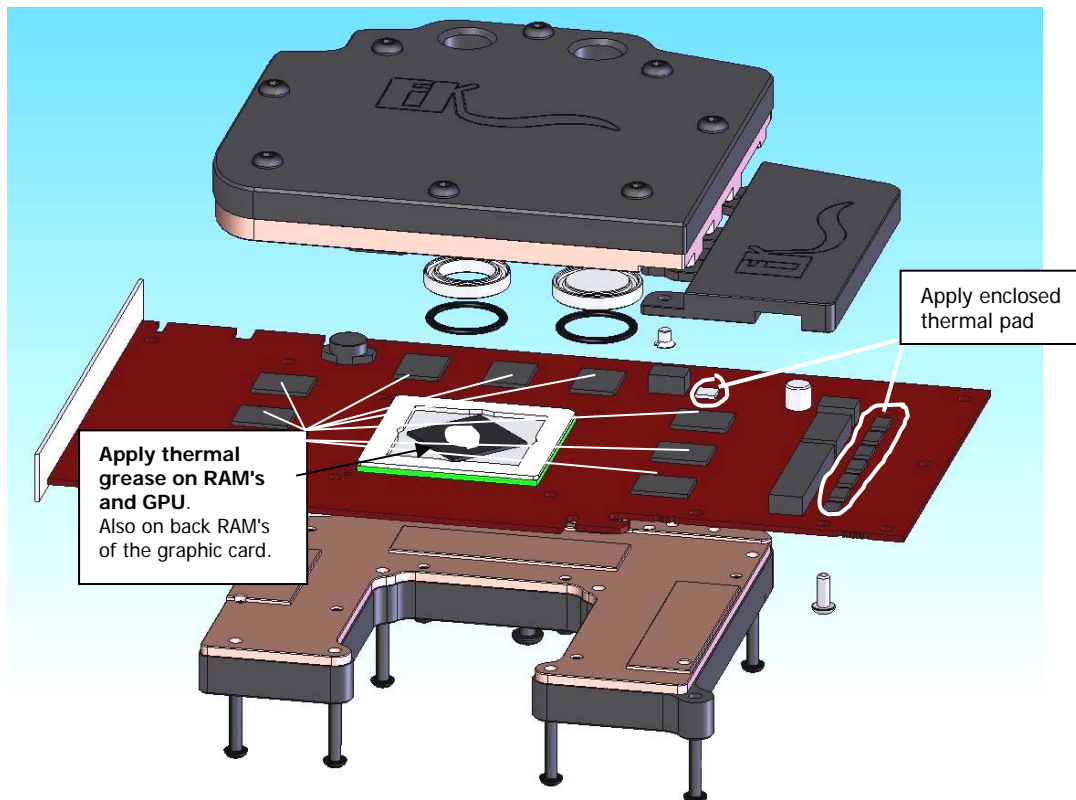

Picture 6: Radeon HD2900 TX series graphic card with assembling view - front side.

#### Step 4.

Place the graphic card between water blocks parts like shown in a picture and screw the water block with enclosed screws.

For perfect contact the block does not mounts with spring system, therefore when installing be very cautious and tighten all screws equally. If the screws are tightened too much the plate of graphic card will bend and might get damaged.

**Start tightening the screws from the GPU and continue outwards. Please use minimum force. Because of screw position if applied too much pressure the graphic card might mend and cause bad contact with water block. If the card bents too much, it might get damaged. Please be very careful especially with tightening mosfet cooler with M3×6 screws.**

**Step 5.** Remove the block and check for contact surface. Then repeat steps 3 and 4. And apply more or less pressure on area where you have found it necessary.

**Step 6.** Connecting the water-block(s) to the cooling circuit and attaching the tubes:

The EK-FCR600 CF Xtreme series are usually sold with high flow fittings included. To insecure the tubes stays properly on the fittings please use hose clamps or appropriate substitute. The use of an algacide is nonetheless recommended in any liquid cooling system.

#### **VERY IMPORTANT NOTICE**

Once the installation is completed, it is always a good idea to test the circuit for leaks, prior to powering up the computer. We recommend a 24 hour leak test prior to powering up the computer. Do not test the water block using city water pressure. This will bow the top of the housing and render the block unusable (and will void your warranty).

#### **IMPORTANT DISCLOSURES:**

While all efforts have been made to provide the most comprehensive tutorial possible, EK Water Blocks assumes no liability expressed or implied for any damage(s) occurring to your components as a result of using EK Water Blocks cooling products, either due to mistake or omission on our part in the above instructions, or due to failure or defect in the EK Water Blocks cooling products.

#### **WARRANTY:**

Our products are guaranteed for 24 months from the date of delivery to the final user against defects in materials or workmanship. During this period, they will be repaired or have parts replaced provided that: (I) the product is returned to the agent from which it was purchased; (II) the product has been purchased by the end user and not used for hire purposes; (III) the product has not been misused, handled carelessly, or other than in accordance with any instructions provided with respect to its use. This guarantee does not confer rights other than those expressly set out above and does not cover any claims for consequential loss or damage. This guarantee is offered as an extra benefit and does not affect your statutory rights as a consumer. **The guarantee is not valid if there are used aggressive UV additives.**